

UVLX - 800 WATT AMALGAM SYSTEMS

UV System	UVLX 3800-10	UVLX 6800-14	UVLX 16800-20	UVLX 30800-30
Performance				
3rd Party Validation	USEPA UVDGM (2006)			
Certification	CE Marked			
UV lamps and monitoring				
Lamp Power	800 W	800 W	800 W	800 W
Lamp Number	3	6	16	30
Lamp Life	16,000 Hours			
Lamp Design	TWISTLOK™ PLUS quick Release, Enhanced Safety - 800 Watt High Output Amalgam Low Pressure			
Validated UV Monitoring	Validated ÖNORM UV Monitor - AT-900 (Calibrated) - IP66			
Variable Power	100% Power to 30% Power (Variable Automatic Dose Pacing)			
UV Chamber				
Connection Size (mm/inch)	DN200/8"	DN250/10"	DN400/16"	DN600/24"
Connection Type	BS4504 PN10 RF Flange			
Design Pressure	7 Barg Design (10.5 Barg Test)			
Material Construction	316L Stainless Steel			
Internal / External Finish	0.8 µm Ra Internal / Bead Blasted			
Lamp and Wiper Access	Single Ended Access			
Quartz Type	High Purity Quartz Thimble			
Mounting	Legs			
Wiper System	Automatic Wiper System			
Temperature Probe	AT-487 (PT-100) - IP66			
Vent & Drain Ports	Yes			
Access Hatch	Yes			
Ingress Protection	IP66			
Installation	Horizontal			
Chamber Options	0.8 µm Ra Internal Polish Upgrade / Electropolish Upgrade / Super Duplex 25% Chrome Steel / Connection Types			

Spectra II / Spectra II Touch - Local Control Cabinet				
Design	Epoxy Coated Mild steel - IP54 Standard			
Control Type	Microprocessor			
Interface	Soft Touch Push Button with 4 Line Text Display / 7" Touch Screen HMI		7" Touch Screen HMI - Full Colour Display	
Communication Options	Ethernet / Modbus / Data Stream (other fieldbus options available)			
Lamp Power Supply	800 Watt Electronic Ballast			
Power Consumption	2,640 W	5,280 W	14,080 W	26,400 W
Mains power	230 V (Other Voltages Available)		400 V (Other Voltages Available)	
Power Requirements	1 Phase + Neutral + Earth		3 Phase + Neutral + Earth	
Frequency	50 Hz (60 Hz Optional)			
Protection	Door Locked Isolator, MCB Protection			
Operating Temperature	Max Working Ambient +45 °C			
Operational Information	Please See SPECTRA II Data Sheet (Upgrade to Spectra II Touch Optional)			

KEY FOOTPRINT DIMENSIONS

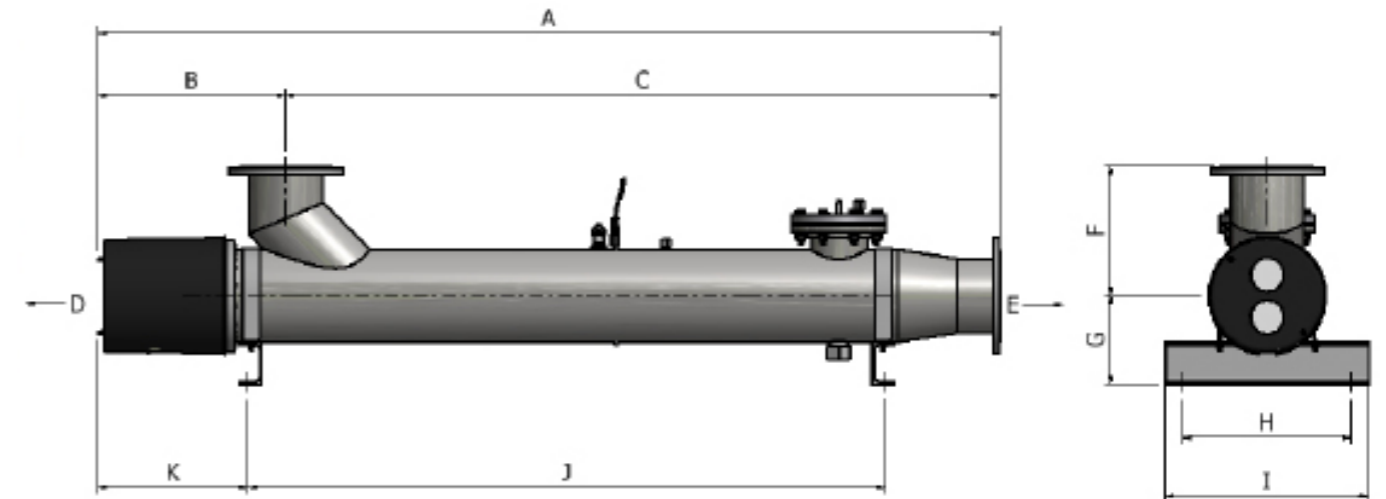

* For full dimensions please see the specific GA drawing.

UV System	UVLX 3800-10	UVLX 6800-14	UVLX 16800-20	UVLX 30800-30
Chamber dimensions				
A	2663 mm	2796 mm	3079 mm	3092
B	554 mm	586 mm	666 mm	806
C	2108 mm	2210 mm	2413 mm	2286
D	1640 mm	1640 mm	1640 mm	1640
E	N/A	N/A	N/A	N/A
F	381 mm	483 mm	635 mm	889
G	262 mm	303 mm	379 mm	506
H	500 mm	510 mm	700 mm	900
I	600 mm	600 mm	800 mm	1000
J	Adjustable			
K	444 mm	475 mm	479 mm	493
Dry Weight	175 kg	335 kg	460 kg	1145 kg
Wet Weight	285 kg	640 kg	1110 kg	2330 kg

Spectra II - Dimensions				
Width	700 mm	700 mm	1400 mm	2000 mm
Height	1800 mm	1800 mm	2000 mm	2000 mm
Depth	500 mm	500 mm	600 mm	600 mm
Weight	210 kg	210 kg	680 kg	950 kg
Standard Cable Length	6 metres			
Maximum Cable Distance	Other Cable Lengths Available On Request			